



SUPER FULL TANK

Hydraulic swing gate operator for heavy duty gate applications



The Most Powerful Operator on the market

19" stroke

1" rod diameter

Max torque 2500 daNm

Hydraulic slowdown

Leaf length up to 30 Ft or 4400 Lbs



Release system protected by metal lock with release key at the inside



Round joint for stroke adjustment



Front flange in solid machined aluminium



Back flange in solid machined aluminium

- ▶ Oil lubrication of all mechanical components
- ▶ Anti crushing guaranteed through by-pass valves for max. thrust adjustment
- ▶ Standard, oscillating aluminium back fixing fork
- ▶ Hydraulic distributor made of machine aluminium bar
- ▶ AC version with lock in opening and closing
- ▶ Ideal for applications in windy sites, heavy duty gate and high security places
- ▶ All-aluminium structure with high-resistance anodising treatment

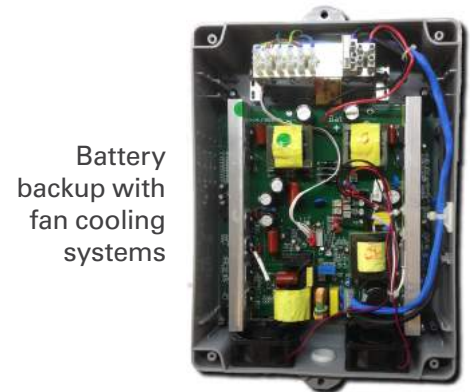

Battery backup with fan cooling systems

SPECIFICATIONS	SUPER FULL TANK
Power supply	120V (±5%) 50/60 Hz
Power Consumption (W)	310 W
Operating T° range (F°)	-4°F to 131°F
Opening time 90° (sec)	IP 55
Cycles/hour	70
Duty	Commercial-industrial
Protection class	IP55
Max leaf length	30 Ft
Max leaf weight	4.500 Lbs
Max opening angle (degrees)	90°/120°
Maximum force output	2500 daNm
Anti-crushing protection	By pass/Electronic
Limit switch	-
Slowdown	Hydraulic
Battery backup	STAR 1000

UNIGATE - I

INVERTER technology



UNIGATE 2I (INVERTER)

- Digital control unit with LCD display
- Adjustable speed
- Adjustable acceleration/deceleration
- Continuous motor cycles
- High strength in slowdown
- Possibility to manage obstacle reverse

Integrated functions on the UNIGATE INVERTER

- 2 relay contacts
- 2 programmable GPIO outputs
- LE card on board for potentiometer
- Relay card on board
- PROBE heater card on board
- Management of two FV inverters for 2 motors or 2 PM modules for 4 motors
- Timer on board with buffer battery and management of 2 time bands
- 2 Ah switching transformer of which about 1.3 Ah free for other accessories



Advantages:

- + Duty cycles
- + Torque
- + Speed (adjustable)
- + one model 90V to 265V

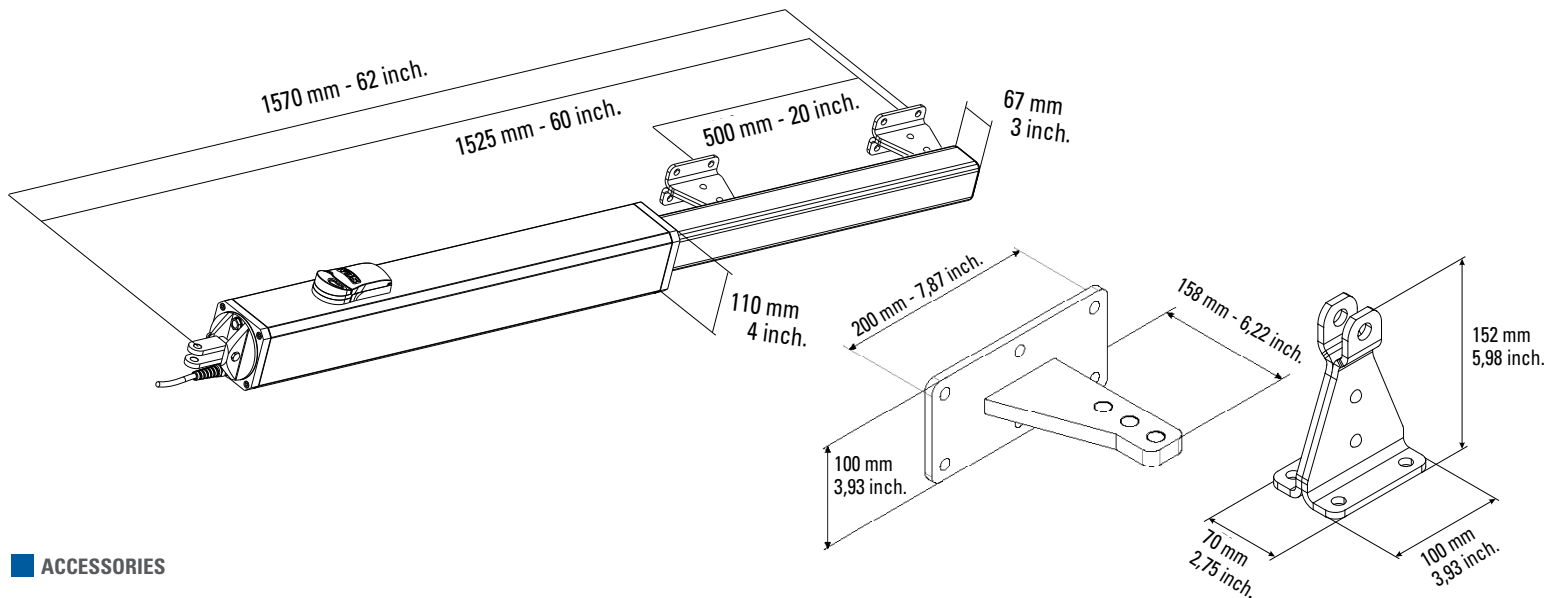

ACCESSORIES



Magnetic Lock



Kit Probe to manage low temperature + card LE + cable 6 Ft



Electric lock Counter-plate for horizontal or vertical mounting external and internal cylinder



Green oil (1 quarter of bottle)

PACKAGE SUPER FULL TANK

N.1 SUPER FULL TANK

Pallet 39x10,6x6,6 H inches - 60 Lbs

12 pcs for pallet