



TAURUS CHAIN

Chain sliding motor for gate up to **800 LBS**



Available also model without limit switches



Led light (optional)



Release system through robust nylon lever and metal lock performance



Adjustable bracket for chain magnetic limit

- Die-cast aluminum body with cathoporesis treatment
- Optional micro-switch on release lever
- Electronic anti-crushing clutch
- Mechanical limit switch
- Adjustable slowdown in opening and closing
- Led light in option on all models
- Release system with robust aluminium lever and metal lock
- Nice design, compact and easy to install

SMALL FEATURES	TAURUS CHAIN
Power Supply (V)	120V ac
Power Consumption (W)	1/3 HP
Operating T° range (F°)	-4°F/131°F
Opening time 90° (sec)	6 inches/sec
Duty cycles	30 %
Duty*	residential
Max gate weight (pound)	800
Max Gate length (feet)	20
Anti-crushing protection	encoder/electronic clutch
Operator weight	28 lbs approx.

GATE 1 DG

- Management of one 115 Vac motor
- Adjustable slowdown in opening and closing
- Adjustable pedestrian opening
- Led warning lamp
- Connector for radio RF receiver plug-in
- Working time self-learning
- Encoder management
- Simplified programming with buttons and display
- Inversion on obstacle with encoder
- Balanced or standard safety edge management
- Separate torque adjustment for opening and closing
- Programming through JOLLY 3 palm also
- Automatic, security and step by step type 1, step by step type 2, 2 buttons, dead-man logics
- Motor inversion and limit switch (right/left hand mounting)
- Automatic closing adjustment
- Start in pause adjustment
- Prepared for Master/Slave function
- Adjustable courtesy light output up to 4 minutes
- Setting number of cycles for assistance
- Settable photocell inputs
- Extractable terminals
- Photocell self-test
- Management of photocells 10K
- ...and many other functions

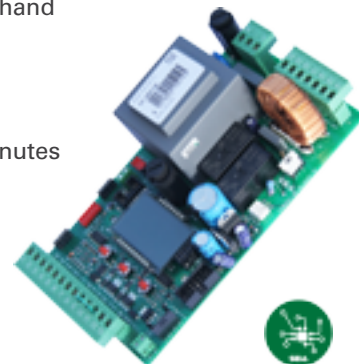

ACCESSORIES



Adjustable bracket for chain magnetic limit

Dimensions (inches)

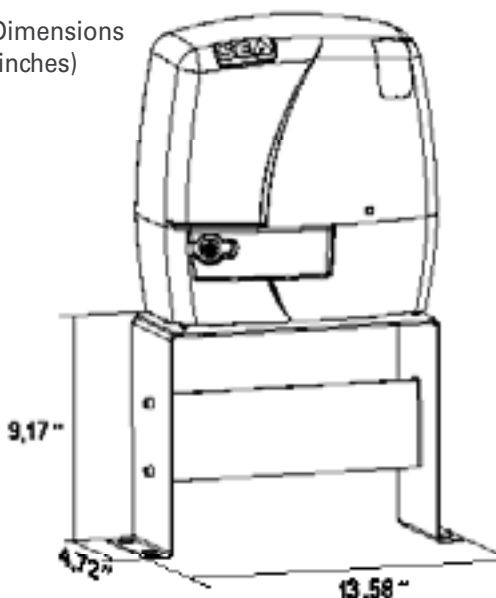

PACKAGE Taurus CHAIN

N.1 Taurus CHAIN with control board
N.20 Feet of chain (type 40)
N.1 Receiver
N.1 Remote control 433 Mhz
N.1 Foundation plate
N.1 Installation accessories Kit
N.1 Installation instructions and general notice
N.1 Warning signboard
1 pc Pallet 14x9x H14 inches - 41 LBS
40 pcs for pallet